

## 1.2A,30V,1.2MHz Step-Down Converter

### DESCRIPTION

The EUP3458 is current mode, step-down switching regulator capable of driving 1.2A continuous load with excellent line and load regulation. The EUP3458 can operate with an input voltage range from 4.5V to 30V and the output can be externally set from 0.8V to 15V with a resistor divider.

Fault protection includes cycle-by-cycle current limiting and thermal shutdown. In shutdown mode the regulator draws 1 $\mu$ A of supply current. Internal soft-start minimizes the inrush current and the output overshoot.

The EUP3458 is available in SOT23-6 and TSOT23-6 packages.

### FEATURES

- 1.2A Output Current
- 0.3 $\Omega$  Internal DMOS Output Switch
- 4.5V to 30V Input Operating Range
- Output Adjustable from 0.8V to 15V
- Up to 92% Efficiency
- 1 $\mu$ A Shutdown Current
- Fixed 1.2MHz Frequency
- Thermal Shutdown and Overcurrent Protection
- Input Supply Undervoltage Lockout
- Available in SOT23-6 and TSOT23-6 Packages
- RoHS Compliant and 100% Lead(Pb)-Free Halogen-Free

### APPLICATIONS

- Distributed Power Systems
- Battery Charger
- Pre-Regulator for Linear Regulators
- WLED Drivers

### Typical Application Circuit

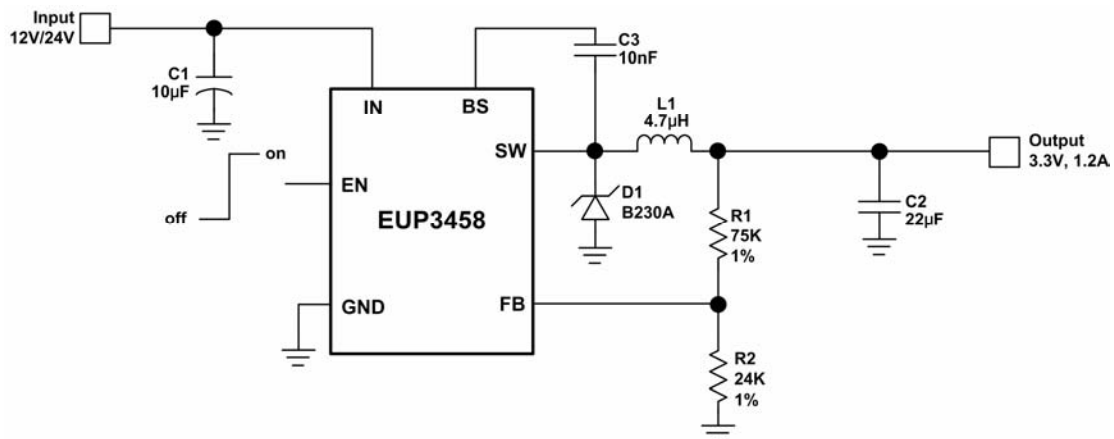
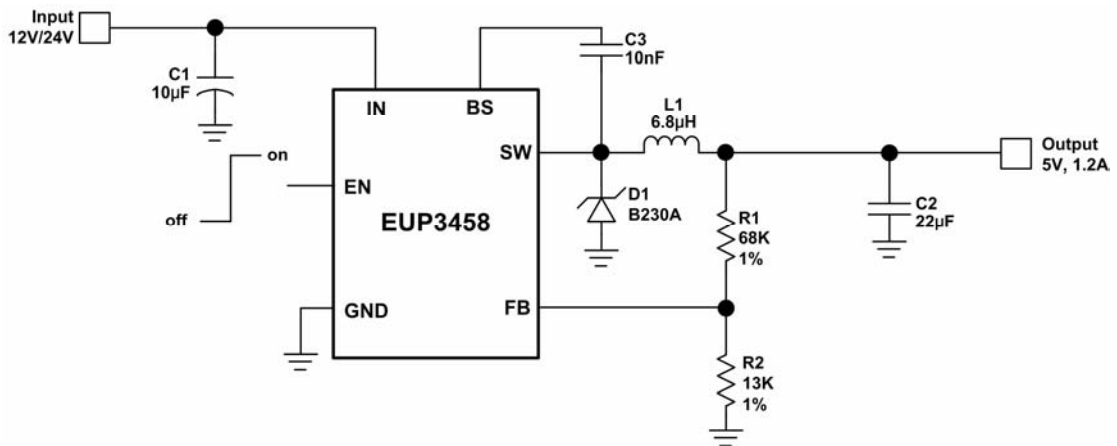

Figure 1. 12V/24V to 3.3V Application Circuit

**Typical Application Circuit (continued)**



**Figure 2. 12V/24V to 5V Application Circuit**

**Pin Configurations**

Package Type	Pin Configurations
SOT23-6 TSOT23-6	<p>(TOP VIEW)</p>

**Pin Description**

Pin Name	SOT23-6	TSOT23-6	DESCRIPTION
BS	1	1	High-Side Gate Driver Bootstrap Supply. BS provides power to the gate driver of n-channel MOSFET switch. Connect a 10nF or greater capacitor from SW to BS.
GND	2	2	Ground. This pin is the voltage reference for the regulated output voltage. It should be kept away from the D1 and input capacitor for noise prevention.
FB	3	3	Output Feedback Input. FB senses the output voltage to regulate that voltage. Connect FB to an external resistor divider to set the output voltage. The value of the divider resistors also set loop bandwidth.
EN	4	4	Enable Input. EN is a logic input that controls the regulator on or off. Drive EN logic high to turn on the regulator, and set EN logic low to turn it off. Don't leave EN pin floating. Directly connect EN to IN (or through a resistance) for automatic startup.
IN	5	5	Input Supply Pin. IN supplies the power to the IC and the power switch. Connect IN to a 4.5V to 30V power source. Bypass IN to GND with a suitably large value capacitor to minimize input ripple to the IC.
SW	6	6	Power Switcher Output. Connect the output LC filter from SW to the output.

**Ordering Information**

Order Number	Package Type	Marking	Operating Temperature Range
EUP3458VIR1	SOT23-6	XXXXX AZ00	-40°C to +85°C
EUP3458OIR1	TSOT23-6	XXXXX AZ00	-40°C to +85°C

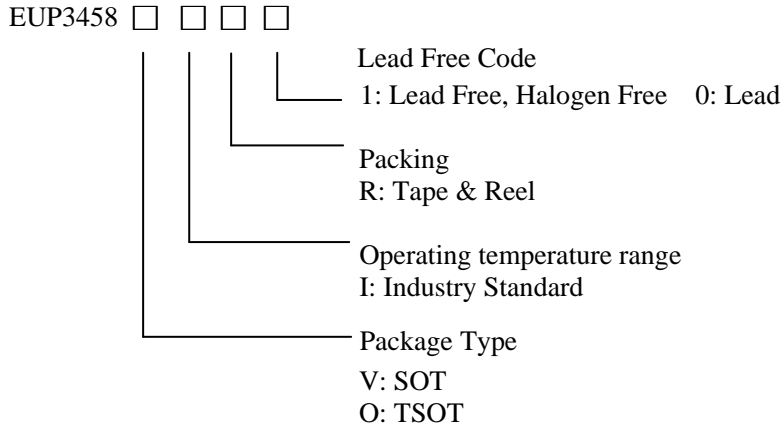

**Block Diagram**

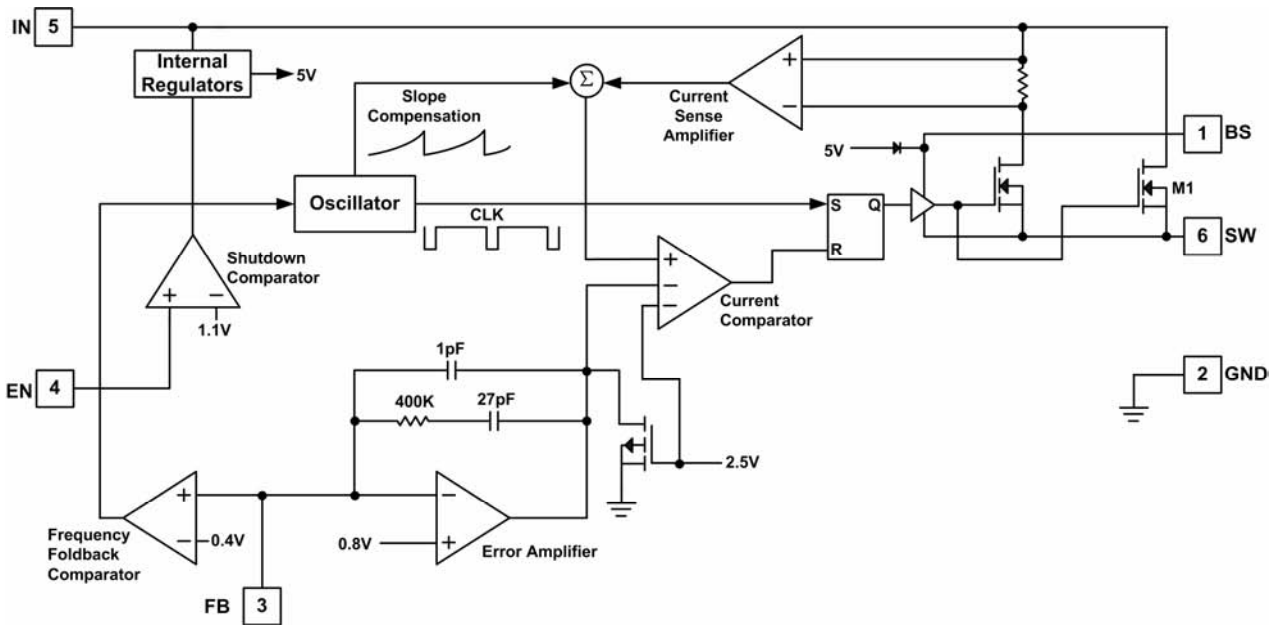

**Figure 3. Functional Block Diagram**

**Absolute Maximum Ratings (1)**

- Input Voltage ( $V_{IN}$ ) ----- -0.3V to 35V
- Enable Input ( $V_{EN}$ ) ----- -0.3V to 35V
- Switch Voltage ( $V_{SW}$ ) ----- -1V to  $V_{IN}+0.3V$
- Boot Strap Voltage ( $V_{BS}$ ) -----  $V_{SW}-0.3V$  to  $V_{SW}+6V$
- All Other Pins ----- -0.3V to 6V
- Junction Temperature ----- 150°C
- Storage Temperature ----- -65°C to +150°C
- Lead Temp (Soldering, 10sec) ----- 260°C
- Thermal Resistance  $\theta_{JA}$  (SOT23-6) ----- 205°C/W
- Thermal Resistance  $\theta_{JA}$  (TSOT23-6) ----- 200°C/W

**Recommend Operating Conditions (2)**

- Supply Voltage ( $V_{IN}$ ) ----- 4.5V to 30V
- Operating Temperature Range ----- -40°C to +85°C

Note (1): Stress beyond those listed under “Absolute Maximum Ratings” may damage the device.

Note (2): The device is not guaranteed to function outside the recommended operating conditions.

**Electrical Characteristics**

The ● denote specifications which apply over the full operating temperature range, otherwise specifications are  $T_A=+25^\circ\text{C}$ .  $V_{EN}=5V$ ,  $V_{IN}=12V$  unless otherwise specified.

Parameter	Conditions	EUP3458			Unit	
		Min.	Typ.	Max.		
Feedback Voltage	$4.5V \leq V_{IN} \leq 30V$		0.784	0.800	0.816	V
		●	0.776	0.800	0.824	
Shutdown Supply Current	$V_{EN}=0V$		1	5	$\mu\text{A}$	
Operating Supply Current	$V_{EN}=2V, V_{FB}=1V, V_{BS}=10V$		0.55	1	mA	
Switch On Resistance			0.3		$\Omega$	
Switch Leakage	$V_{EN}=0V, V_{SW}=0V$			5	$\mu\text{A}$	
Switch Peak Current Limit		1.6	2.1		A	
Oscillator Frequency		1	1.2	1.4	MHz	
Short Circuit Frequency	$V_{FB}=0V$		450		KHz	
Maximum Duty Cycle	$V_{FB}=0.7V$		90		%	
Minimum On-Time			100		ns	
Enable Low Voltage				0.4	V	
Enable High Voltage		1.5				
Input Undervoltage Lockout Threshold	In Rising	3.3	3.6	3.9	V	
Input Undervoltage Lockout Threshold Hysteresis			300		mV	
Enable Leakage Current	$V_{EN}=0V$		0.1	5	$\mu\text{A}$	
Thermal Shutdown			165		$^\circ\text{C}$	

**Typical Operating Characteristics**

$V_{IN}=12V$ ,  $V_{OUT}=3.3V$ ,  $C1=10\mu F$ ,  $C2=22\mu F$ ,  $L1=4.7\mu H$ ,  $T_A=25^\circ C$ , unless otherwise noted.

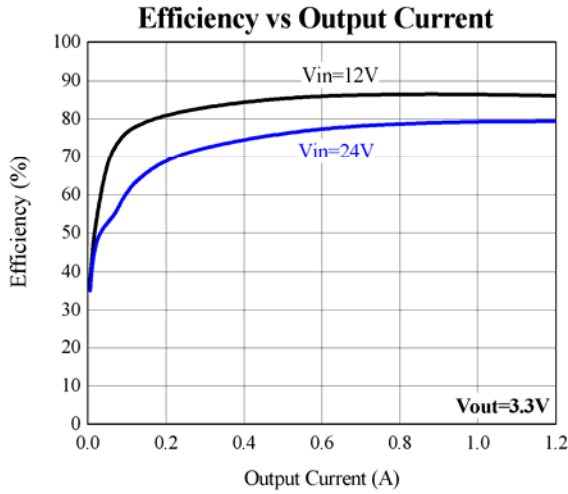

Figure4.

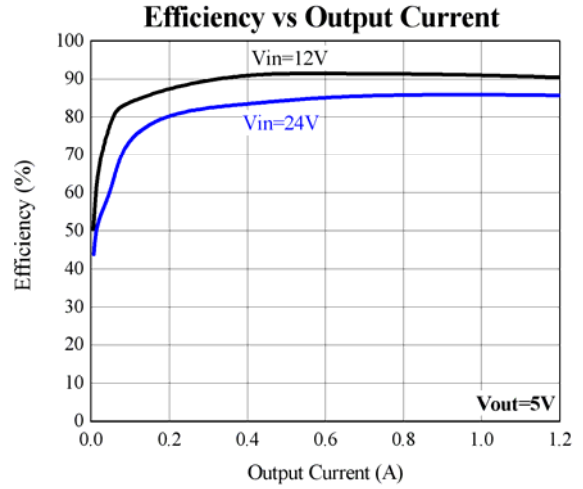

Figure5.

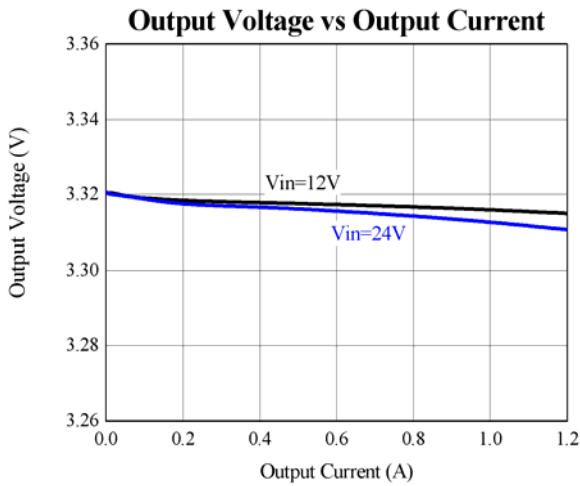

Figure6.

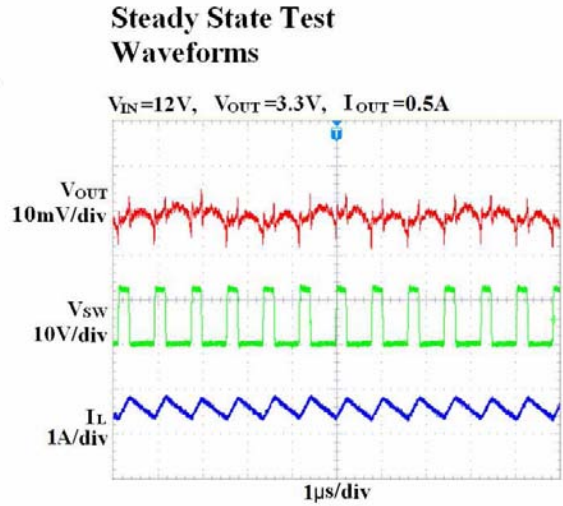

Figure7.

**Startup through Enable Waveforms**

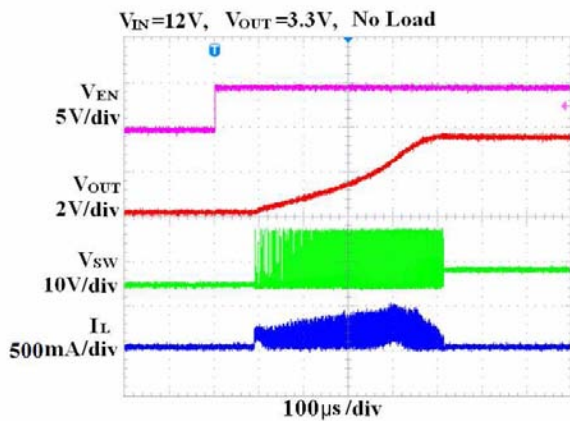

Figure8.

**Startup through Enable Waveforms**

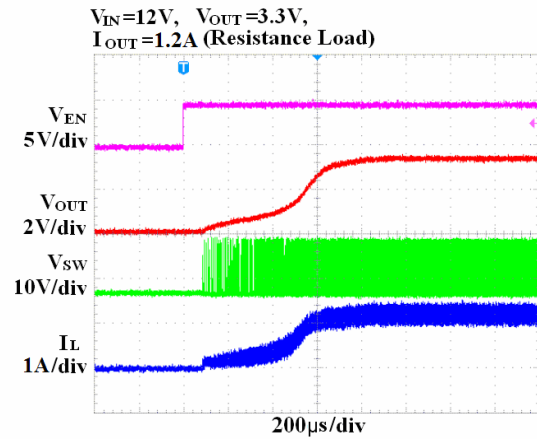

Figure9.

**Typical Operating Characteristics (continued)**

$V_{IN}=12V$ ,  $V_{OUT}=3.3V$ ,  $C1=10\mu F$ ,  $C2=22\mu F$ ,  $L1=4.7\mu H$ ,  $T_A=25^\circ C$ , unless otherwise noted.

**Shutdown through Enable Waveforms**

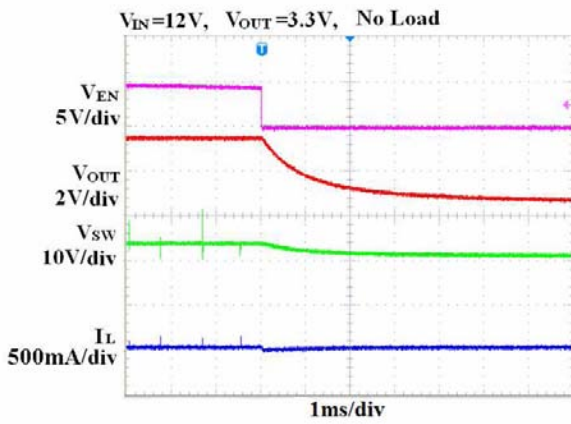

Figure10.

**Shutdown through Enable Waveforms**

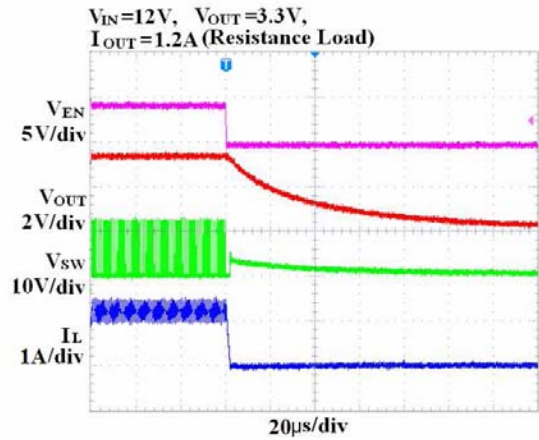

Figure11.

**Short Circuit Test Waveforms**

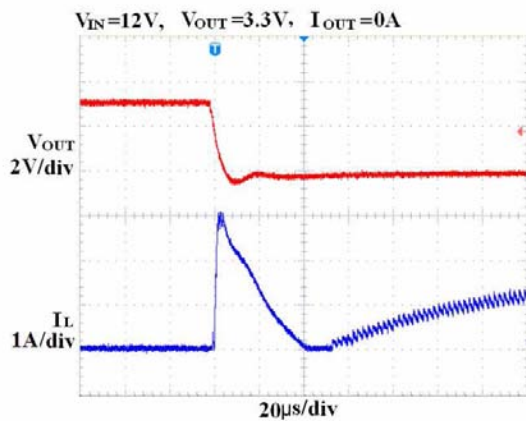

Figure12.

**Short Circuit Recovery Waveforms**

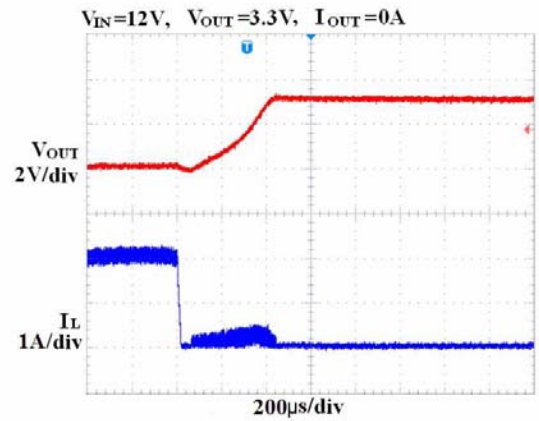

Figure13.

**Short Circuit Test Waveforms**

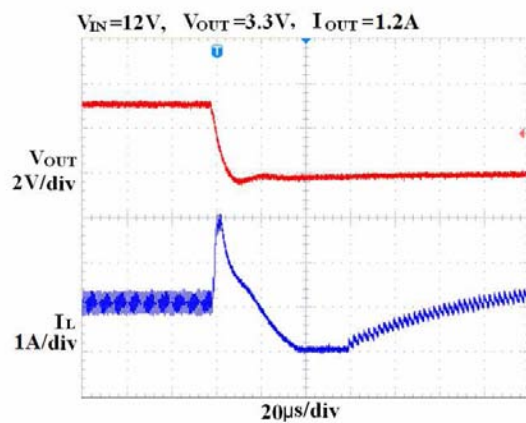

Figure14.

**Short Circuit Recovery Waveforms**

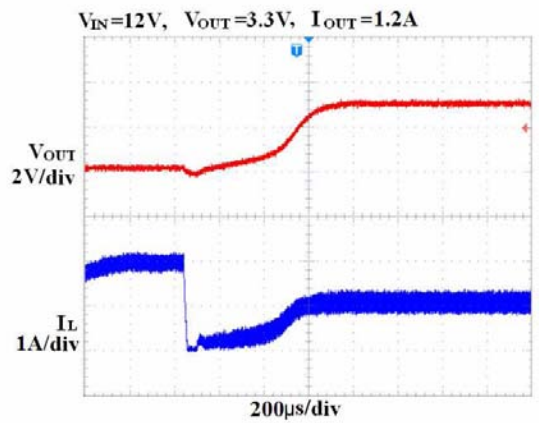

Figure15.

**Typical Operating Characteristics (continued)**

$V_{IN}=12V$ ,  $V_{OUT}=3.3V$ ,  $C1=10\mu F$ ,  $C2=22\mu F$ ,  $L1=4.7\mu H$ ,  $T_A=25^\circ C$ , unless otherwise noted.

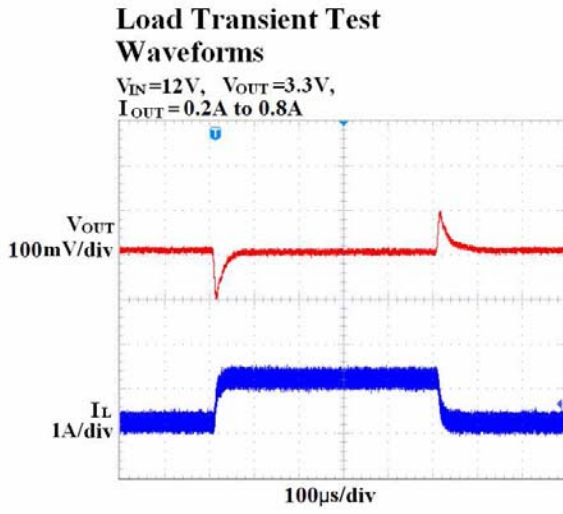

Figure16.

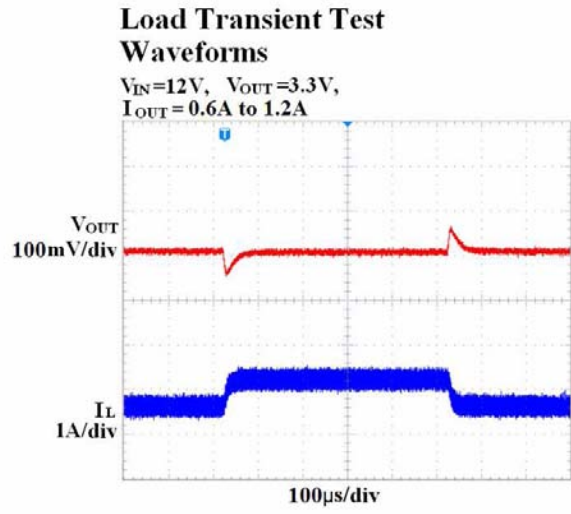

Figure17.

**Functional Description**

The EUP3458 is current-mode step-down switching regulator. The device regulates an output voltage as low as 0.8V from a 4.5V to 30V input power supply. The device can provide up to 1.2Amp continuous current to the output. The EUP3458 uses current-mode architecture to control the regulator loop. The output voltage is measured at FB through a resistive voltage divider and amplified through the internal error amplifier.

Slope compensation is internally added to eliminate subharmonic oscillation at high duty cycle. The slope compensation adds voltage ramp to the inductor current signal which reduces maximum inductor peak current at high duty cycles.

The device uses an internal n-channel switch to step down the input voltage to the regulated output voltage. Since the n-channel switch requires gate voltage greater than the input voltage, a bootstrap BS capacitor is connected between SW and BS to drive the n-channel gate.

**Application Information**

**Setting the Output Voltage**

The output voltage is set through a resistive voltage divider (see Figure1 or 2). The voltage divider divides the output voltage down by the ratio:

$$V_{FB} = V_{OUT} * R2 / (R1 + R2) = 0.8V$$

Thus the output voltage is :

$$V_{OUT} = 0.8V * (R1 + R2) / R2$$

The feedback resistor R1 also sets the feedback loop bandwidth with the internal compensation capacitor. R2 can be determined by:

$$R2 = R1(V_{OUT} / 0.8 - 1)$$

**Inductor**

The inductor is required to supply constant current to the output load while being driven by the switched input voltage. A larger value inductor results in less ripple current and lower output ripple voltage. However, the larger value inductor has a larger physical size, higher series resistance, and lower saturation current. Choose an inductor that does not saturate under the worst-case load conditions. A good rule for determining the inductance is to allow the peak-to- peak ripple current in the inductor to be approximately 30% of the maximum load current. Also, make sure that the peak inductor current (the load current plus half the peak-to-peak inductor ripple current) is below the 2A minimum peak current limit.

The inductance value can be calculated by the equation:

$$L = (V_{OUT}) * (V_{IN} - V_{OUT}) / (V_{IN} * f * \Delta I)$$

Where  $V_{OUT}$  is the output voltage,  $V_{IN}$  is the input voltage,  $f$  is the switching frequency, and  $\Delta I$  is the peak-to-peak inductor ripple current.

**Input Capacitor**

The input current to the step-down converter is discontinuous, and therefore an input capacitor C1 is required to supply the AC current to the step-down converter while maintaining the DC input voltage. A low ESR capacitor is required to keep the noise minimum at the IC. Ceramic capacitors are preferred, but tantalum or low-ESR electrolytic capacitors may also suffice. The input capacitor value should be greater than 10µF, and the RMS current rating should be greater than approximately 1/2 of the DC load current. In Figure 1 or 2, all ceramic capacitors should be placed close to the EUP3458.

**Output Capacitor**

The output capacitor is required to maintain the DC output voltage. Low ESR capacitors are preferred to keep the output voltage ripple low. The characteristics of the output capacitor also affect the stability of the regulator control loop. In the case of ceramic capacitors, the impedance at the switching frequency is dominated by the capacitance. For most application, a 22µF ceramic capacitor will be sufficient.

**Output Rectifier Diode**

The output rectifier diode supplies the current to the inductor when the switch is off. A schottky diode is recommended to reduce losses due to the diode forward voltage and recovery times. The reverse voltage rating of the diode should be greater than the maximum input voltage, and current rating should be greater than the maximum load current.

**External Bootstrap Diode**

An external bootstrap diode may improve the efficiency when input voltage is lower than 5.5V or duty cycle is higher than 65%. The external 5V can be a 5V fixed input from system or a 5V output of the EUP3458.

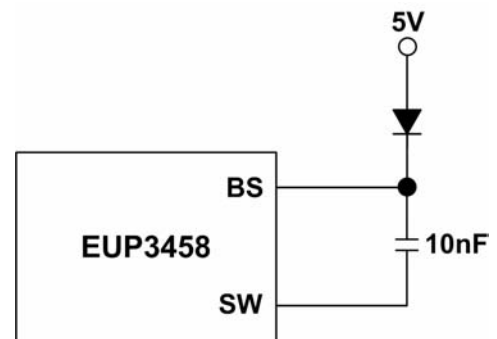



**Thermal Considerations**

To avoid the EUP3458 from exceeding the maximum junction temperature, the user will need to do a thermal analysis. The goal of the thermal analysis is to determine whether the operating conditions exceed the maximum power dissipation which can be calculated by following formula:

$$P_{L(MAX)} = (T_{J(MAX)} - T_A) / \theta_{JA}$$

Where  $T_{J(MAX)}$  is the maximum operation junction temperature,  $T_A$  is the ambient temperature and the  $\theta_{JA}$  is the junction to ambient thermal resistance.

**Table 1. External components for typical designs**

Vin(V)	Vout(V)	L1( $\mu$ H)	C2( $\mu$ F)	R1(K $\Omega$ )	R2(K $\Omega$ )
5	1.2	2.2	22	180	360
5	1.8	3.3	22	62	49.9
12	1.8	3.3	22	62	49.9
12	3.3	4.7	22	75	24
12	5	6.8	22	68	13
24	3.3	4.7	22	75	24
24	5	6.8	22	68	13

To simplify design efforts using the EUP3458, the typical designs for common applications are listed in Table 1.

**Packaging Information**

**SOT23-6**

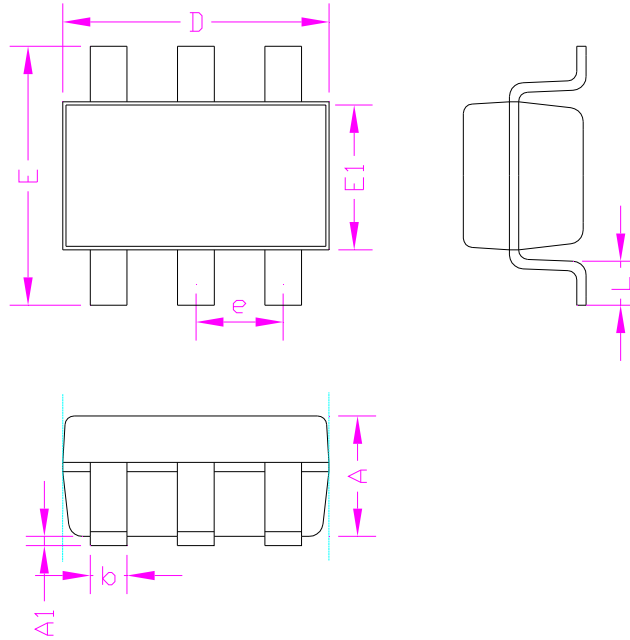

SYMBOLS	MILLIMETERS		INCHES	
	MIN.	MAX.	MIN.	MAX.
A	-	1.45	-	0.057
A1	0.00	0.15	0.000	0.006
b	0.30	0.50	0.012	0.020
D	2.90		0.114	
E1	1.60		0.063	
e	0.95		0.037	
E	2.60	3.00	0.102	0.118
L	0.3	0.60	0.012	0.024

**TSOT23-6**

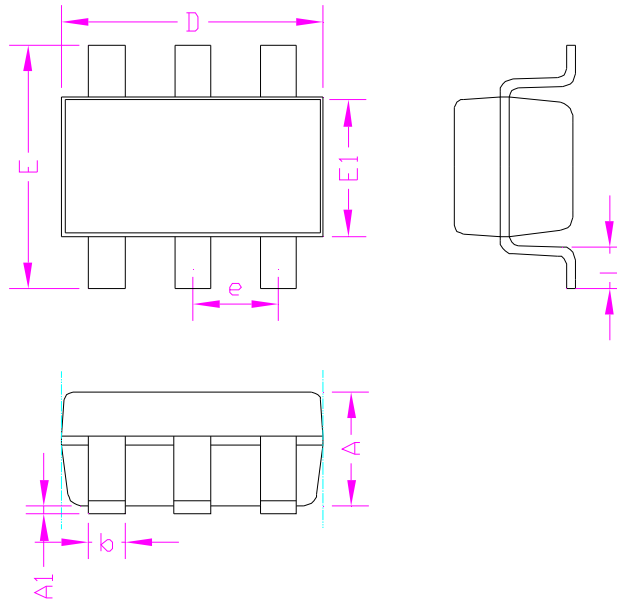

SYMBOLS	MILLIMETERS		INCHES	
	MIN.	MAX.	MIN.	MAX.
A	-	1.00	-	0.039
A1	0.00	0.15	0.000	0.006
b	0.30	0.50	0.012	0.020
D	2.90		0.114	
E1	1.60		0.063	
e	0.95		0.037	
E	2.60	3.00	0.102	0.118
L	0.3	0.60	0.012	0.024